

Thank you for ordering your Stainless Steel Style Bar from MX5 Parts.

Before you start

1. Ensure the handbrake is on and the car is on a flat surface.

Tools required

You will require the following tools:

1. 10, 13, 15 16 & 17mm Spanner or socket
2. 13mm Spanner or socket
3. Philips Screwdriver
4. Torque wrench

Product/fitings supplied:**Parts supplied:**

1. Style Bar
2. Windblocker
3. Retaining strap x 3
4. Rubber spacer x 3
5. Windblocker storage bag
6. Bolt x 2
7. Spacer x 2
8. Instructions

How to fit

1. Start by removing the seatbelt bolt from the seatbelt towers (Fig.1) and remove the washers (c) and spacers (b) from the bolt (Fig.2).

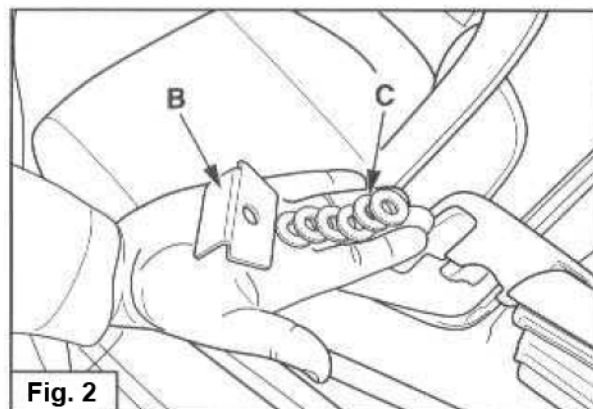
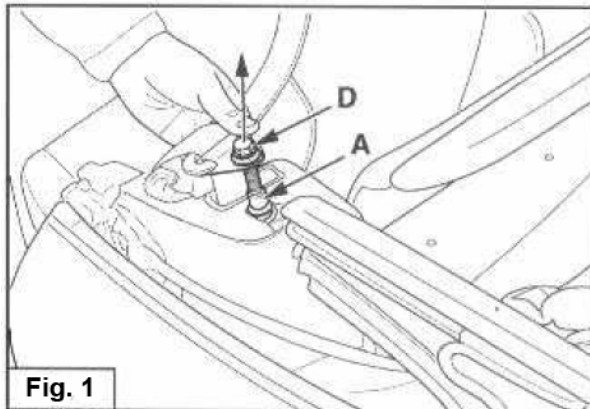

2. If fitting to a Mk2/2.5 that has the factory windblocker, follow Fig.3, if fitting to a Mk1, or Mk2/2.5 without the factory windblocker, see Fig.4 and remove the bolt marked 'A'

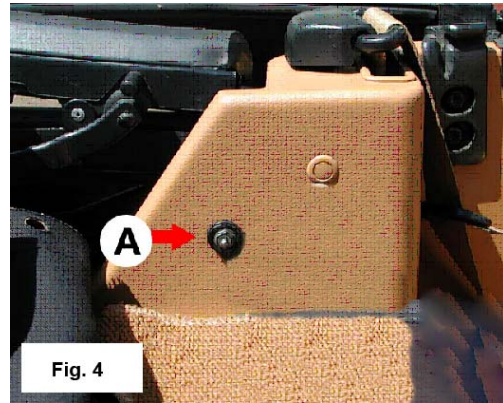
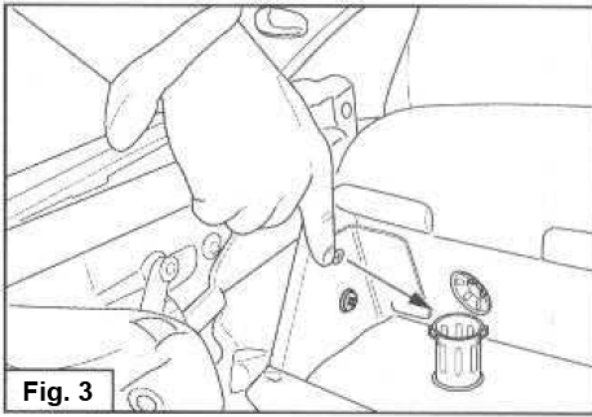

3. Using the washers/spacers that you removed from the seatbelt bolt (Fig.5), replace them in to the seatbelt tower so that the finished height of the washers/spacers allows the Style Bar to sit flat on the top of the tower. This is just a matter of trial and error as every car has a different combination of spacers and washers fitted at the factory (Fig.6).

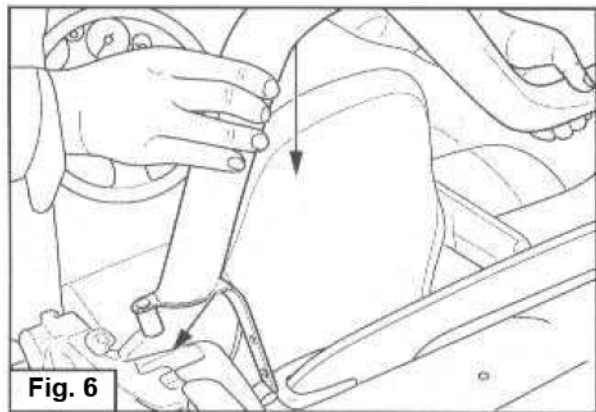
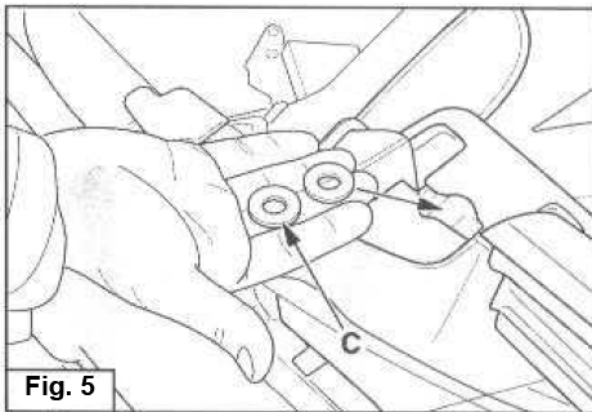

4. Place the spacer tube supplied with the Style Bar on to the seatbelt bolt together with a washer (Fig.7) and pass it down through the Style Bar, and the washers/spacers into the seatbelt tower (Fig.8). If you are happy that everything lines up and the bar is sitting nicely on the top of the tower, tighten the Seatbelt bolt with your fingers (do not tighten it fully at this stage).

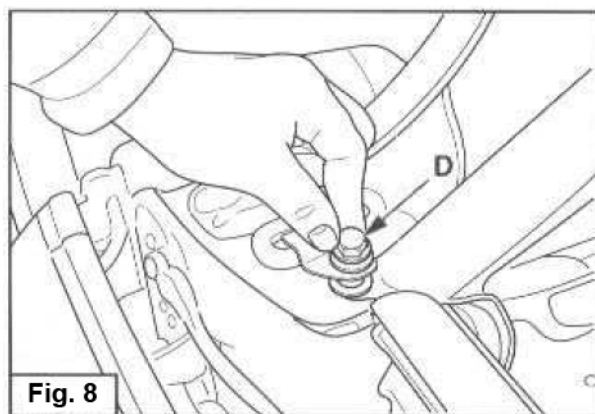
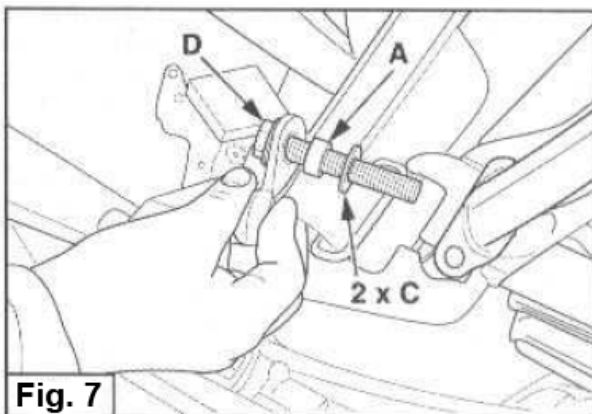

5. If fitting to a Mk2/2.5 with the factory fitted windblocker, replace the bolt 'A' in Fig.9. If fitting to a Mk1 or a Mk2/2.5 without a factory fitted windblocker, replace the bolt removed in 2 ('A' in Fig.4).

6. Only if fitting to a Mk2/2.5 with the factory fitted windblocker, fit the supplied bolt together with the washer removed in Fig.3 to the fixing illustrated in Fig10.

If you wish to use this additional fixing when fitting to a Mk1, you will need to drill a suitable hole and source a suitable bolt, washer and nut. We do not use this additional fixing when we fit these Style Bars in our workshop.

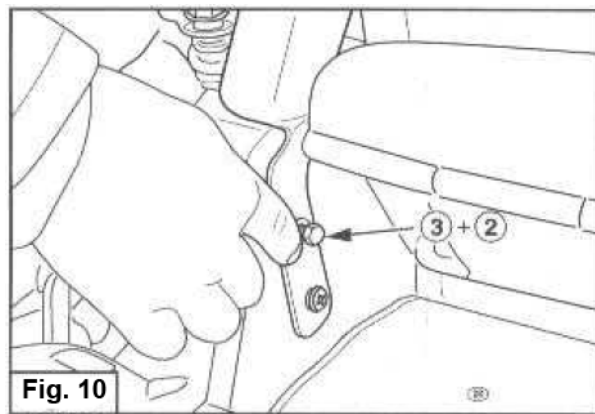
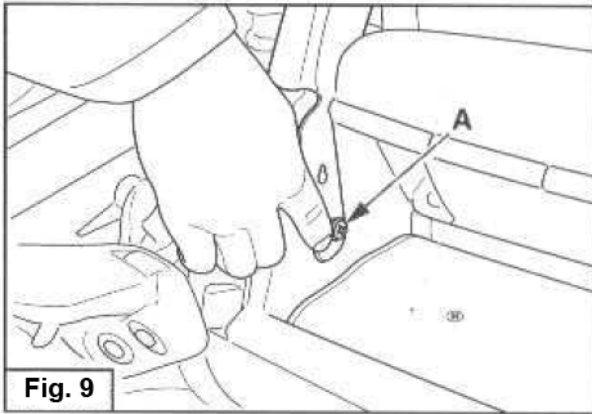

7. Tighten the Seatbelt bolt to 79Nm and the side mountings to 9.6Nm (Fig.11 & 12).

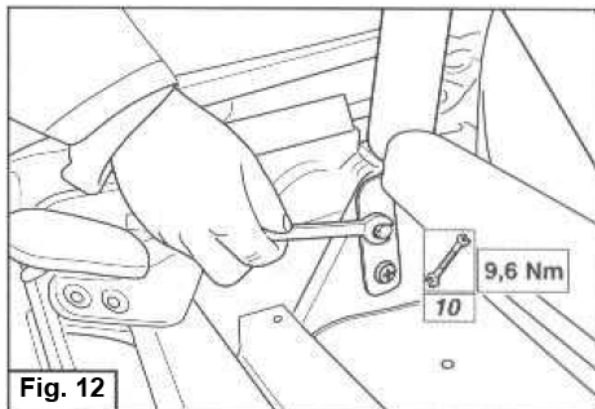
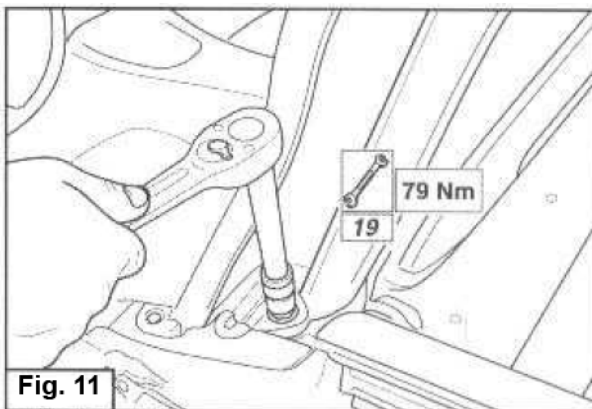

8. Clear away your tools, stand back and admire your handywork ☺.